

User's Manual

Anti-static bar

EasION IQ 4.0 / EasION-A IQ 4.0

EasION IQ 4.1 / EasION-A IQ 4.1

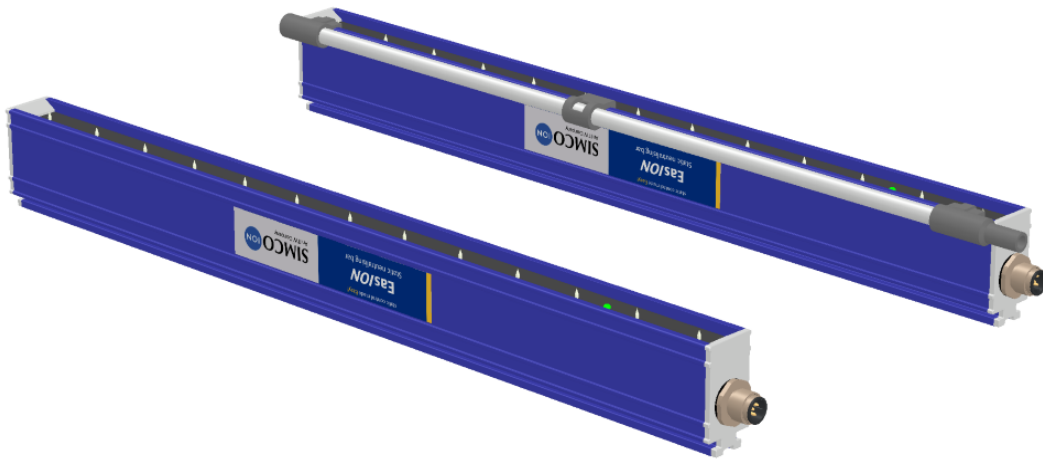

simco.nl/153203



simco.nl/154600





This manual was originally written in English.

The product may have undergone changes that are not reflected in this manual.

Simco (Nederland) B.V.
Aalsvoort 74
7241MB LOCHEM
Phone +31 573 288 333
Email cs@simco-ion.nl
Internet <https://simco-ion.eu/>

Trade register Apeldoorn No. 08046136

2026 © Copyright Simco (Nederland) B.V.

Table of Contents

Explanation of symbols	5
Preface	6
Introduction	7
Device applications	7
Device description	7
Available device versions	8
Names and functions of the device parts	9
Description and operation	10
Checking package contents	10
Two types of operation	10
IQ features	12
Safety	13
Technical specifications	15
Dimensions	20
Installation precautions	21
Checks	21
Installation precautions	21
Mechanical installation	23
Mounting the EasION 4	23
Mounting bracket	23
Inline mounting the EasION 4	28
Electrical connection	29
Connecting the EasION IQ 4.x	29
Commissioning	36
Functional check	40
Causes of overloading	41
Maintenance	42
Troubleshooting	43
Warranty	45
Warranty Period	45
Repairs	46
Return Merchandise Authorisation	46
Storage and disposal	47
Storage	47
Disposal	47

Spare parts	48
Closing	49

Explanation of symbols

The following symbols may appear in this manual or on the product



WARNING Indicates special information to prevent injury or significant damage to the product or the environment



DANGER Indicates information for preventing electric shocks



SHARP EDGES Indicates information for preventing injury by sharp edges



NOTE Important information for making the most efficient use of the product and for preventing damage to the product or the environment



HINT Advice about the use of the product



CLASS II EQUIPMENT with functional earthing



IQ CERTIFIED This product works fully with and is certified for Simco-ION's IQ 4 platform



MANUAL OPERATION The product is connected to a power source. Eventual communication takes place analogously via the connector.



IQ OPERATION The product is used in combination with the IQ 4 platform. The product communicates digitally and is controlled from the platform.

Preface

This manual is intended for the installation and use of the anti-static bars type EasION IQ 4.0, EasION IQ 4.1, EasION-A IQ 4.0, EasION-A IQ 4.1, and EasION IQ 4.1 + Air Knife.

This manual must always be accessible to the operating personnel.

Read this manual completely before installing and commissioning this product.

Instructions in this manual must be followed to ensure proper operation of the product and to make a warranty claim.

The warranty provisions are described in the General Terms and Conditions of Sale of Simco (Nederland) B.V.



NOTE

If there are any problems or doubts, please get in touch with Simco-ION Netherlands or the agent in your region.



NOTE

Product names may be abbreviated in the documentation.

Below the abbreviations and full product names with the link to the relevant documentation.

Abbreviated product name	Full Simco-ION product name	Documentation link
EasION 4 Also named: device, ionizer, bar, anti-static bar, product	EasION IQ 4.0	153203
	EasION IQ 4.1	1546
	EasION-A IQ 4.0	1555
	EasION-A IQ 4.1	1552
	EasION IQ 4.1 + Air Knife	1549/6399
Smart SLC	Smart SLC IQ 4.0	1034
Addition SLC	Addition SLC IQ 4.0	1034
Manager 4	Manager IQ 4.0	1034
Extention 4	Extension IQ 4.0	1034

Introduction

Device applications

The EasION 4 anti-static bar is intended to neutralise electrostatically charged surfaces in production processes.

The device works independently and displays its operating status via the device status LED and via the feedback signal inside the device connector. In chapter Functional check you can read which statuses the device has.

In addition, a Smart SLC 4.0 system can display and log various parameters, limit values, and information on the running or standby operation process.

The functional description of device management can be read in the IQ 4 platform User Manual.

Specific conditions of use

The product is intended to be a part of a machine or process.

The product must NOT be used in a fire or explosion-hazardous environment.

Device description

The device is equipped with an integrated high-voltage power supply, high-voltage emitter pins and a status LED.

The 24 V DC supply voltage is converted into a positive and negative high voltage inside the bar. The high voltage generates an electrical field at the emitters of the bar, which causes the air molecules around the emitters to be converted into positive and negative ions. When an electrostatically charged material comes within operating distance of the device, the emitted ions from the bar are exchanged with the charged material until the material becomes neutralised.

Available device versions

The EasION 4 has the following device versions:

- 1532 03 xxxx EasION IQ 4.0
- 1532 04 xxxx EasION **R** IQ 4.0 (inline mounting)
- 1555 00 xxxx EasION-A IQ 4.0
- 1546 00 xxxx EasION IQ 4.1
- 1546 01 xxxx EasION **C** IQ 4.1 (inline mounting)
- 1546 02 xxxx EasION **R** IQ 4.1 (inline mounting)
- 1549 00 xxxx EasION IQ 4.1 + Air Knife (details see Air Knife user manual)
- 1552 00 xxxx EasION-A IQ 4.1

Names and functions of the device parts

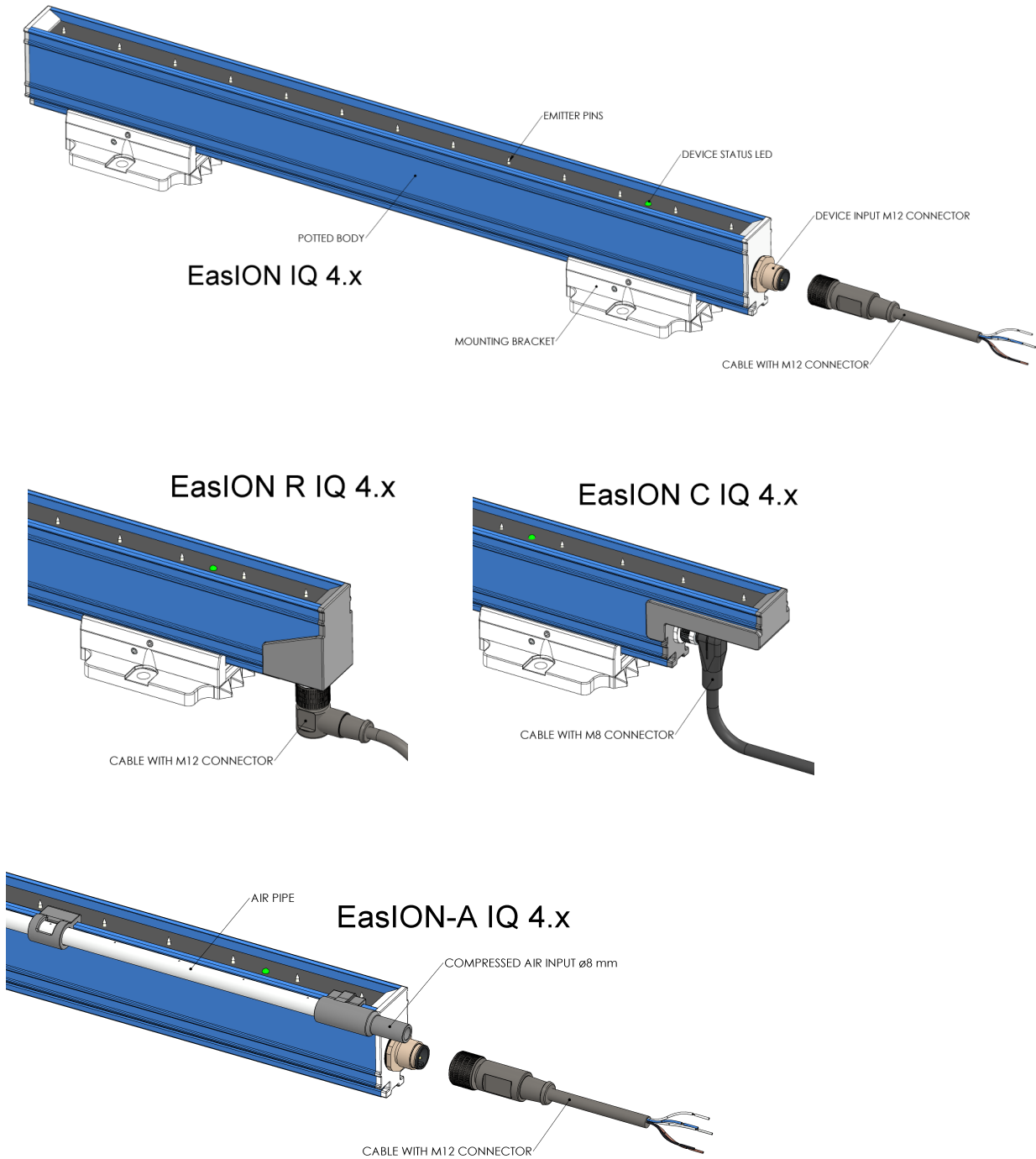

Figure: EasION 4 types

Description and operation

Checking package contents

Device

Mounting brackets

Hex screw driver 2 mm plastic

Warranty card

Memory card with User Manual (Credit card format)

Two types of operation

The EasION 4 can operate stand-alone or within a Simco-ION IQ platform;

- A. EasION IQ 4.0 - works with a Manager IQ Easy 2.0 and a Smart SLC 4.0 or Manager IQ 4.0
- B. EasION IQ 4.1 - works with the Smart SLC 4.0 or Manager IQ 4.0

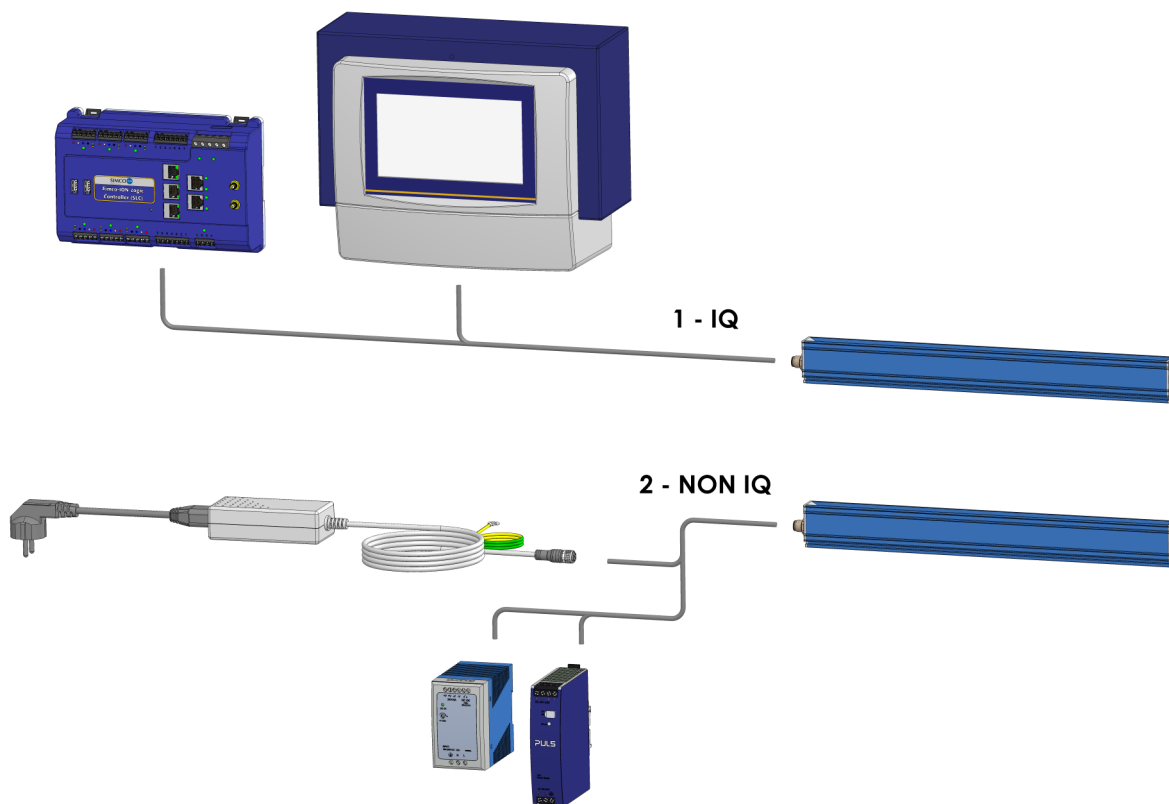



Figure: Two types of operation

The device can be operated in the following conditions:

1		IQ: Operate within the Simco-ION IQ Platform
2		NON-IQ: Manual operation - Stand-alone



IQ OPERATION



IQ CERTIFIED

This Simco-ION product is IQ 4.0 certified. The product can be used within an IQ 4 platform using a Smart SLC 4.0 or Manager IQ 4.0.

The IQ 4 platform is intended to connect Simco-ION devices in order to control all devices from one central location.

The system's core consists of the Smart Simco-ION Logic Controller (SLC), a 'plug and run' control system. The system is based on:

- Smart SLC IQ 4.0
- Addition SLC IQ 4.0
- Manager IQ 4.0
- Extension IQ 4.0

IQ features

IQ 4.0 compatible devices have additional functionalities when combined with a Smart SLC 4.0 or Manager IQ 4.0 system.

The devices provide the following added value (depending on device type):

- central status control and control of the IQ device
- closed loop feedback (CLFB)
- read out parameters
- change parameters
- calibration of efficiency indication
- operation optimisation settings
- data logging
- data graph
- event logging
- automatic device software update

The operation of the device in IQ mode can be read in the Smart SLC 4.0 or Manager IQ 4.0 User Manual.

For individual functionality, refer to the section for the specific device.



MANUAL OPERATION

Connecting the device directly to a 24 V DC power source without IQ system, the device will function as a non-IQ device.

Read the sections Technical specifications and Installation for more information.

Safety

The following safety guidelines must be observed in order to avoid injuries and damage to objects or the product.



WARNING

Electrical installations and repairs must be carried out by a qualified electrician in accordance with national and local regulations.

- The product must not be used in a fire or explosion-hazardous environment.
- The device is intended solely for the electrostatic discharging of non-conductive materials. Any other use is not recommended.
- Metal parts in the vicinity of the product, including machine frames, must be earthed to prevent unwanted charging of the metal parts
- Touching the sharp emitter pins may cause injury.
- A small amount of ozone is emitted during the operation of the product. The ozone concentration is so low that no damage to health can occur.



DANGER

- Never use a damaged product. Touching the live parts will cause an electric shock.
- The power must be turned off before any work on the equipment is started to prevent electric shock.
- The equipment must be properly earthed. Earthing is necessary to ensure proper and safe operation and to prevent electric shocks upon contact.
- Touching high-voltage components results in an electric shock. An electric shock can trigger a shock reaction, even in areas with contact-protected high voltage.
- High-voltage can be dangerous for people with active implanted medical devices for example a pacemaker, insuline pump or coclear implant.



NOTE

- Making modifications, adjustments, etc., without prior written consent or carrying out repairs using non-original parts will invalidate the equipment's guarantee and withdraw the CE approval for the product.

**NOTE**

When the device is connected to a DIN rail power supply or an external power supply:

- For personal protection and to ensure proper functioning, the yellow/green or grey and blue wires must be both connected to earth.
- In the Simco-ION desktop power supply and in the IQ 4 platform these connections are already established.

Technical specifications



IQ OPERATION

Electrical data	
Input type	Smart SLC IQ 4.0 (IQ 4 platform)
	Addition SLC IQ 4.0 (IQ 4 platform)
	Manager IQ 4.0 (IQ 4 platform)
	Extension IQ 4.0 (IQ 4 platform)
Current consumption	Max. 1,0 A DC
Max. cable length	30 m x 0,34 mm ²
Connection	Default: M12 connector, male, 5 pins
	EasION C IQ 4.1: M8 connector, male, 5 pins
Input	
Standard	Full control and readout via IQ 4 platform with an RS485 serial link with standard voltage levels
Output	
Output voltage emitters	Max. 15 kV positive and negative
Current per emitter to earth	Max. 250 µA
IQ 4 platform/IQ Easy platform	RS485 voltage levels



MANUAL OPERATION

Required power supply	
Supply voltage	21 – 27 V DC
Current consumption	Max. 1,0 A DC
Connection	Simco-ION Desktop Power supply: M12 connector, Female, 5-pins or wired to any other power supply
Input	
Remote on/off	10 – 30 V ($R_i > 10k$), 25 mA Starting time: 30 ms
Output	
Output voltage emitters	Max. 15 kV positive and negative
Current per emitter to earth	Max. 250 μ A
High voltage OK (Operation OK) signal	Supply voltage -1 V, max. 50 mA
Signalling (Status LED)	
Continuous green	In operation
Flashing green	Standby
Continuous red	Overload
Flashing red	Operation OK overload



NOTE

The Operation OK logic output(s) are compatible with IEC 61131-2 'Type 1, 2 and 3' PLC inputs.

Power and cabling, operate stand-alone

Input	24V DC $\pm 2\%$	24V DC $\pm 5\%$	24V DC $\pm 10\%$
Standard Simco-ION 5 x 0,34 mm ²	3,125 Ω : 62 m	2,25 Ω : 45 m	0,75 Ω : 15 m
Max. cable length	62 m	45 m	15 m
M12 Male-Female cable	Simco-ION Din-rail Power Supply	Simco-ION Desktop Power supply	-
Starting time with the use of Remote on signal	30 ms when 24 V DC power is continuously on With only the power line connected to 24 V DC, the device will not start up		
Starting time without use of Remote on signal	8 s When remote and 24 V DC are powered up together (NOT Recommended!)		

Mechanical

Effective length	EasION IQ 4.x EasION C IQ 4.1	300 - 4890 mm 360 - 4890 mm
Operating distance	EasION (C/R) IQ 4.x EasION-A IQ 4.x	50 - 500 mm 50 - 1000 mm
Max. material speed	500 m/min	
Min. machine frame distance	50 mm (see Figure: Free area around the bar)	
Weight	1,32 kg/m	

Material

Device part	Material
Casing	PC-ABS/PUR
Emitters	Tungsten
Universal Mounting Bracket	PA66/6

Ambient conditions

Use	Industrial, indoor use
Ingress Protection class	IP66 (Connector properly tightened)
Temperature Ambient (Tamb)	0–55°C
Relative Humidity (RH)	< 90%, non condensing

Air data (EasION-A IQ 4.x)

Compressed air input	
Air filtration	Upstream water separator and oil extraction filter: Industrial use: 20-40 µm Electronic use: 20 µm Pharmaceutical use: 0.01 µm
Compressed air connector	Push-in fitting for hose ø8 mm. Such as Festo Quick Star (QS)
Air pressure	Max. 7 bar (100 PSI)
Pressure vs Flow	See figure Air consumption EasION-A IQ 4.x



NOTE

- The compressed air must be clean and free of moisture and oil.
- Always use the required compressed air filtration according to the Technical specifications.

EASION-A IQ 4.X AIR CONSUMPTION @ EFFECTIVE LENGTHS

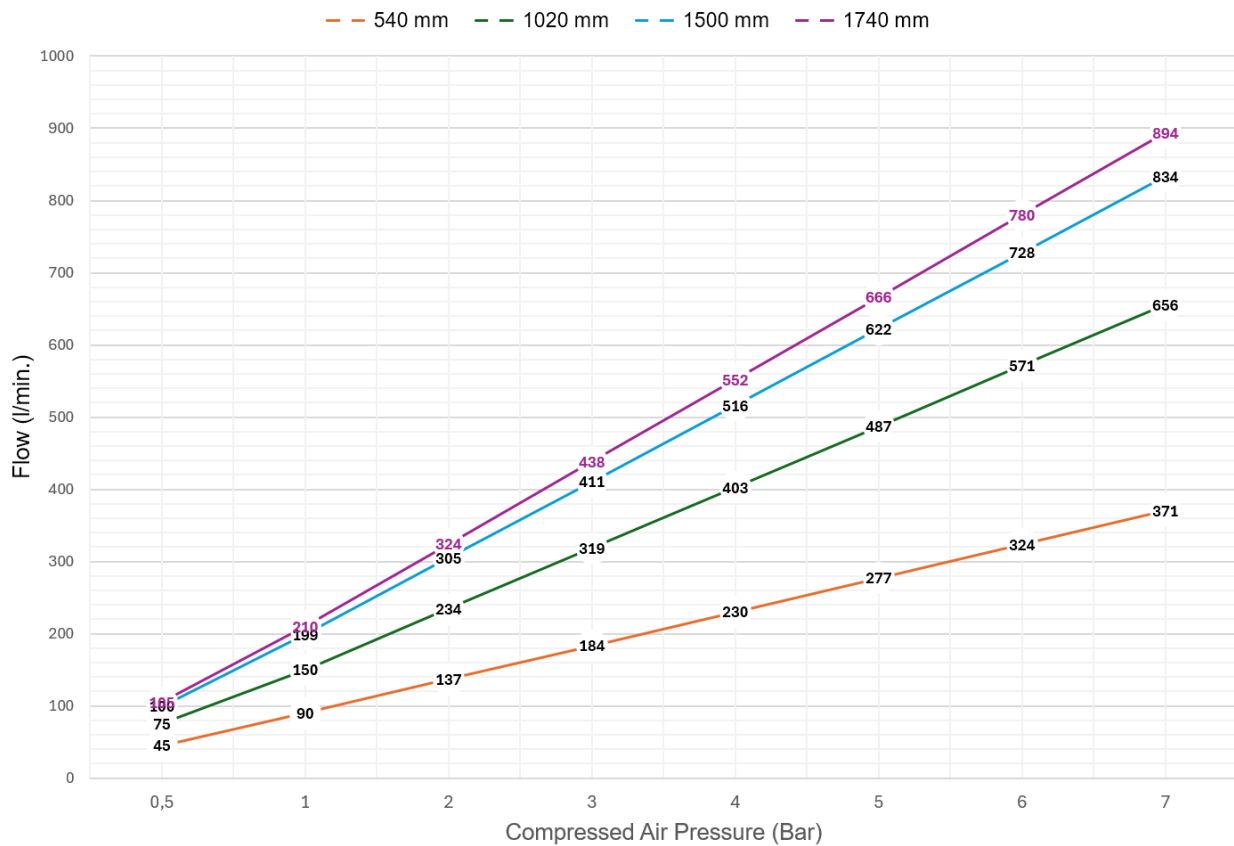

Figure: Air consumption EasION-A IQ 4.x

The graph shows the air consumption of four effective lengths.
For other effective lengths, read the value from the graph by interpolating.
At EasION-A IQ 4.x with effective lengths of 1800 - 3420

- Divide the effective length by 2
- Read the value of this length from the graph by interpolating
- The air consumption is this value x2

Dimensions

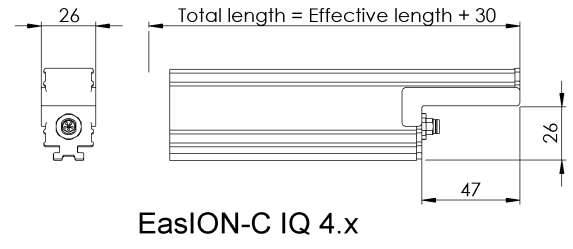
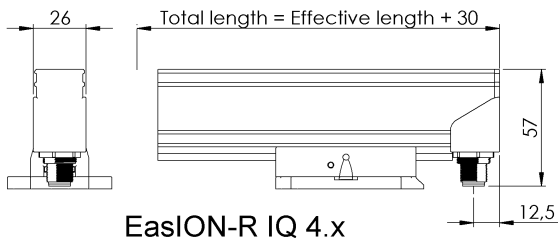
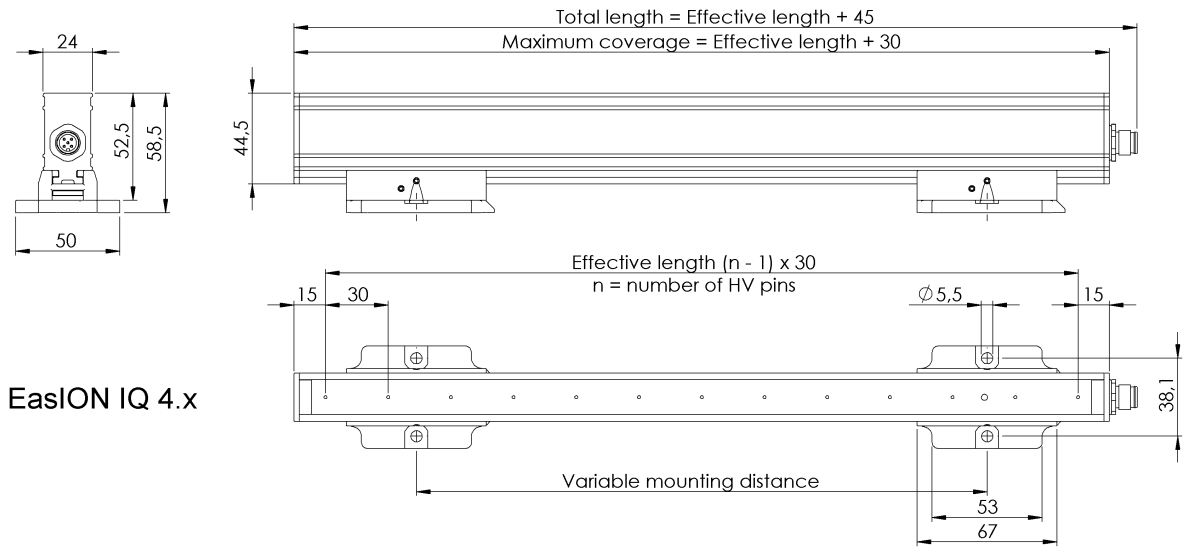

Figure: Dimensions EasION IQ 4.x

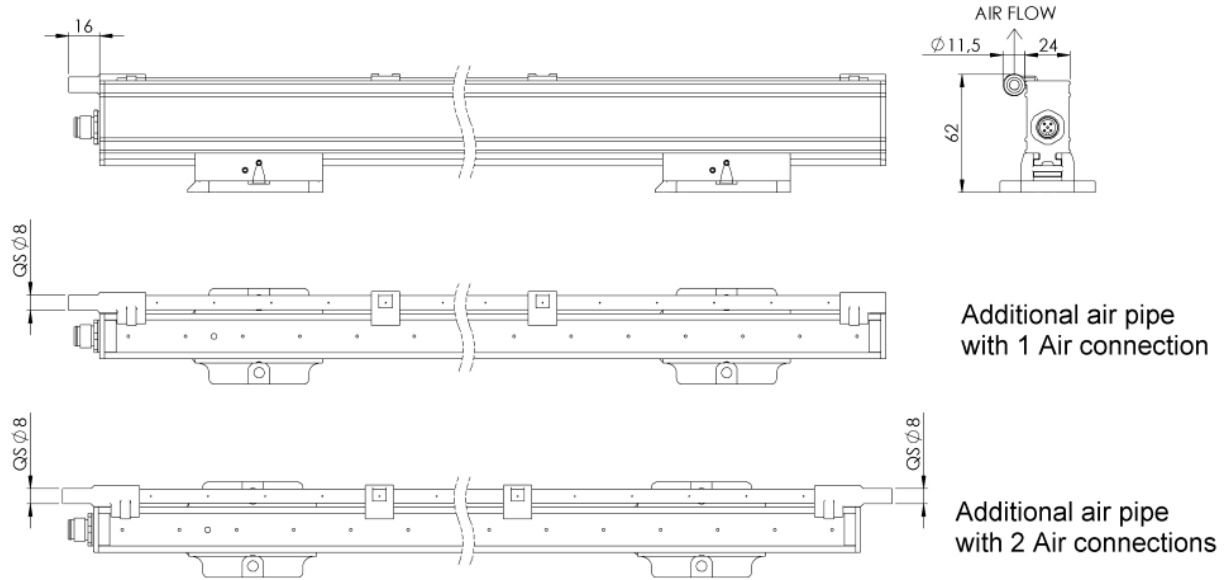

Figure: Dimensions EasION-A IQ 4.x

Installation precautions

Checks

- Check that the device is undamaged and that the correct version has been received.
- Check whether the necessary accessories are included.
- Check whether the details of the packing slip correspond to the details of the product received.



NOTE

If there are any problems or doubts, please get in touch with Simco-ION Netherlands or the agent in your region.

Installation precautions

Device installation location

Conductive machine parts in the vicinity of the device have a negative influence on its performance.

For optimum results, the anti-static bar must be fitted as per figure Free area around the device.

Installation recommendations for the anti-static bar:

- As close as possible, upstream, to the location where static electricity causes a problem.
- The optimum distance from the material to be neutralised is 50 - 500 mm.
 - The neutralising effect decreases when the operating distance increases.
- Ensure there is a free area (R) around the device to prevent environmental influences.
- With the emitters facing in the direction of the material to be neutralised.

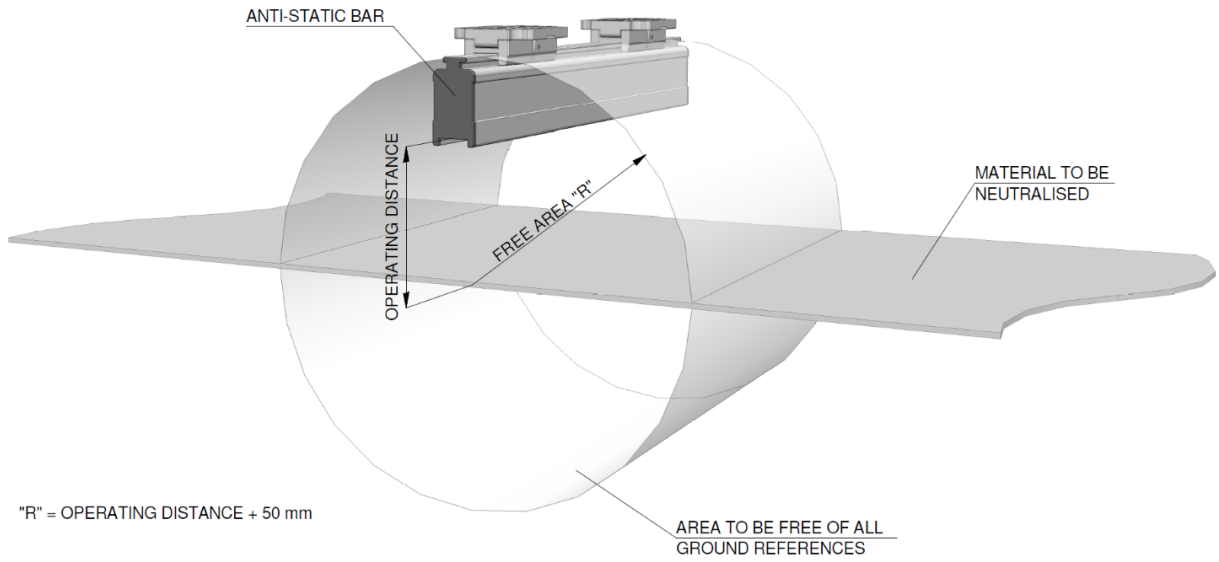

Figure: Free area around the bar

Mechanical installation

Mounting the EasION 4

The EasION 4 is mounted using Simco-ION Mounting Bracket Bars. The number of brackets depends on the device length.

Table: *Number of brackets*

BAR EFFECTIVE LENGTH	QUANTITY
300 - 840	2
900 - 1680	3
1740 - 2460	4
2520 - 3240	5
3300 - 4080	6
4140 - 4920	7

Mounting bracket



NOTE

- When mounting the mounting bracket to the machine, never use a higher wrench torque than 1 Nm. A higher torque may damage the bracket.
- When locking the device and the mounting bracket, never use a higher wrench torque than 0,5 Nm. A higher torque may damage the brackets or the device.

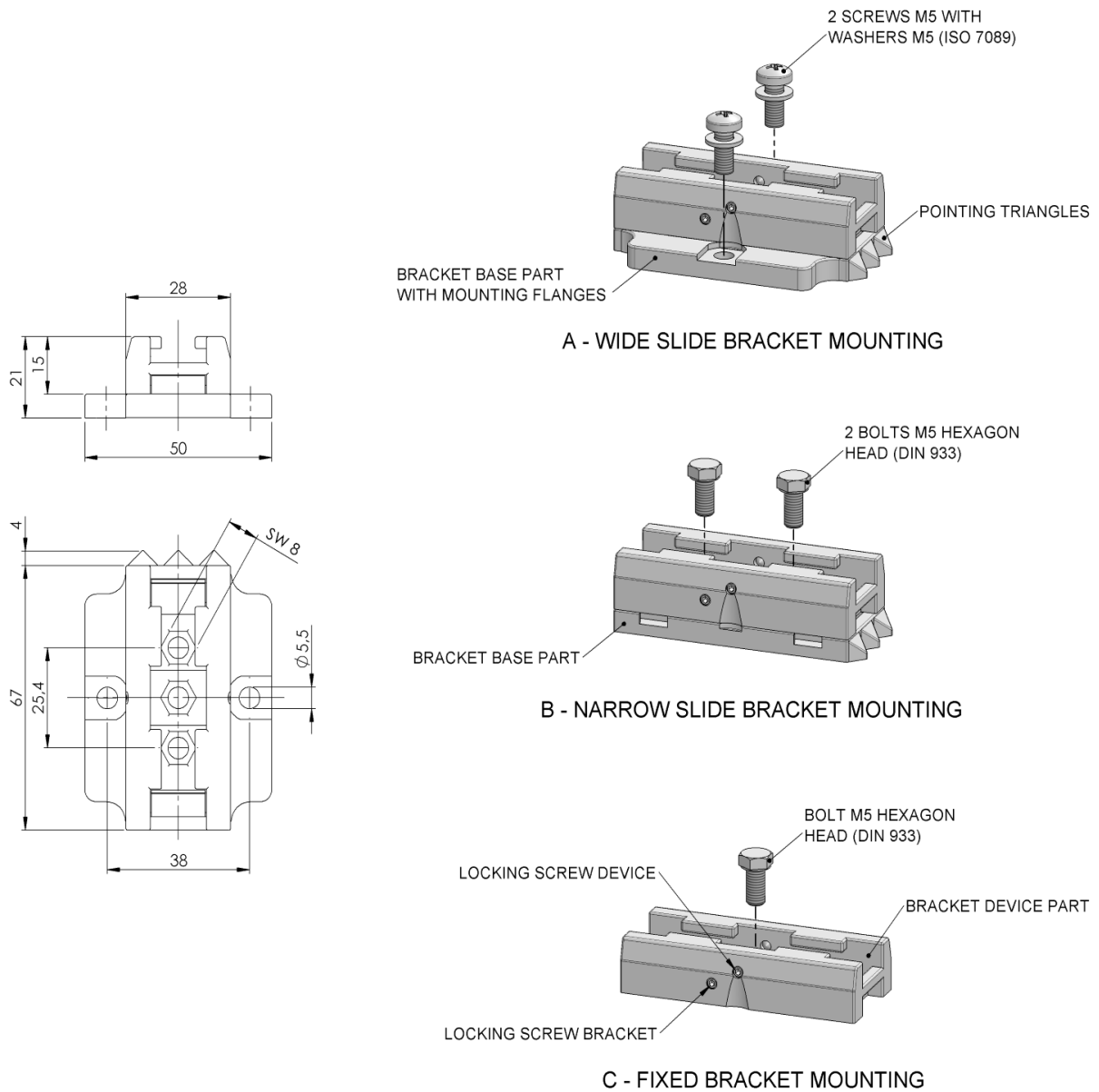

Figure: Mounting bracket



NOTE

When performing mounting options B or C, only use M5 bolts with hexagon head (8 mm key).

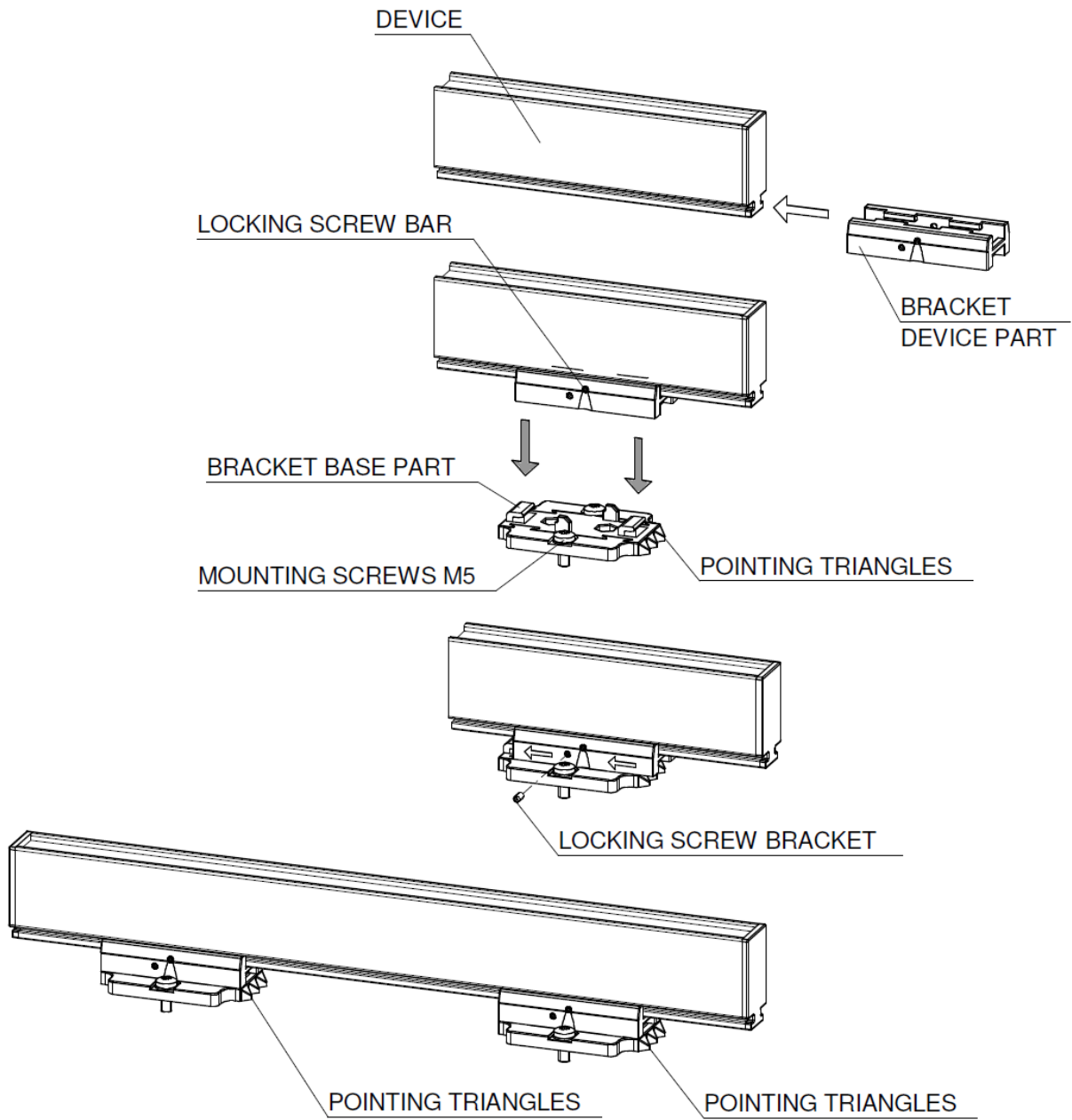

Figure: Mounting the device

Mounting options A and B (slide bracket)

See figures Mounting bracket and Mounting the device.

- Determine the mounting option A or B to attach the mounting bracket base parts to the machine.
- Use appropriate M5 mounting materials to attach the mounting bracket base parts to the machine.

The triangles of the base parts have to point in the same direction.

- Slide the bracket device parts onto the device.

Keep spacings of the bracket device parts and mounting bracket base parts equal, and lock the bracket device parts with the locking screws.

- Place the anti-static bar with the brackets onto the mounting brackets and slide the entire device in the opposite direction of the three triangles until it stops.
- Lock the anti-static bar in the bracket base parts by screwing the two bracket locking screws into the brackets.

Mounting option C (fixed bracket)

See figures Mounting bracket and Mounting the device.

- Place suitable M5 bolts in the bracket device part.
- Slide the bracket device parts onto the device.
- Place the device with the bolts on the desired place and fix the bracket device parts with suitable M5 nuts.
- Adjust the position of the device and lock the bracket device parts with the device locking screws.

Mounting the EasION-A IQ 4.x



NOTE

The compressed air hose(s) must be fixed to the machine frame, to prevent forces to the air connection of the EasION-A IQ 4.x air pipe.

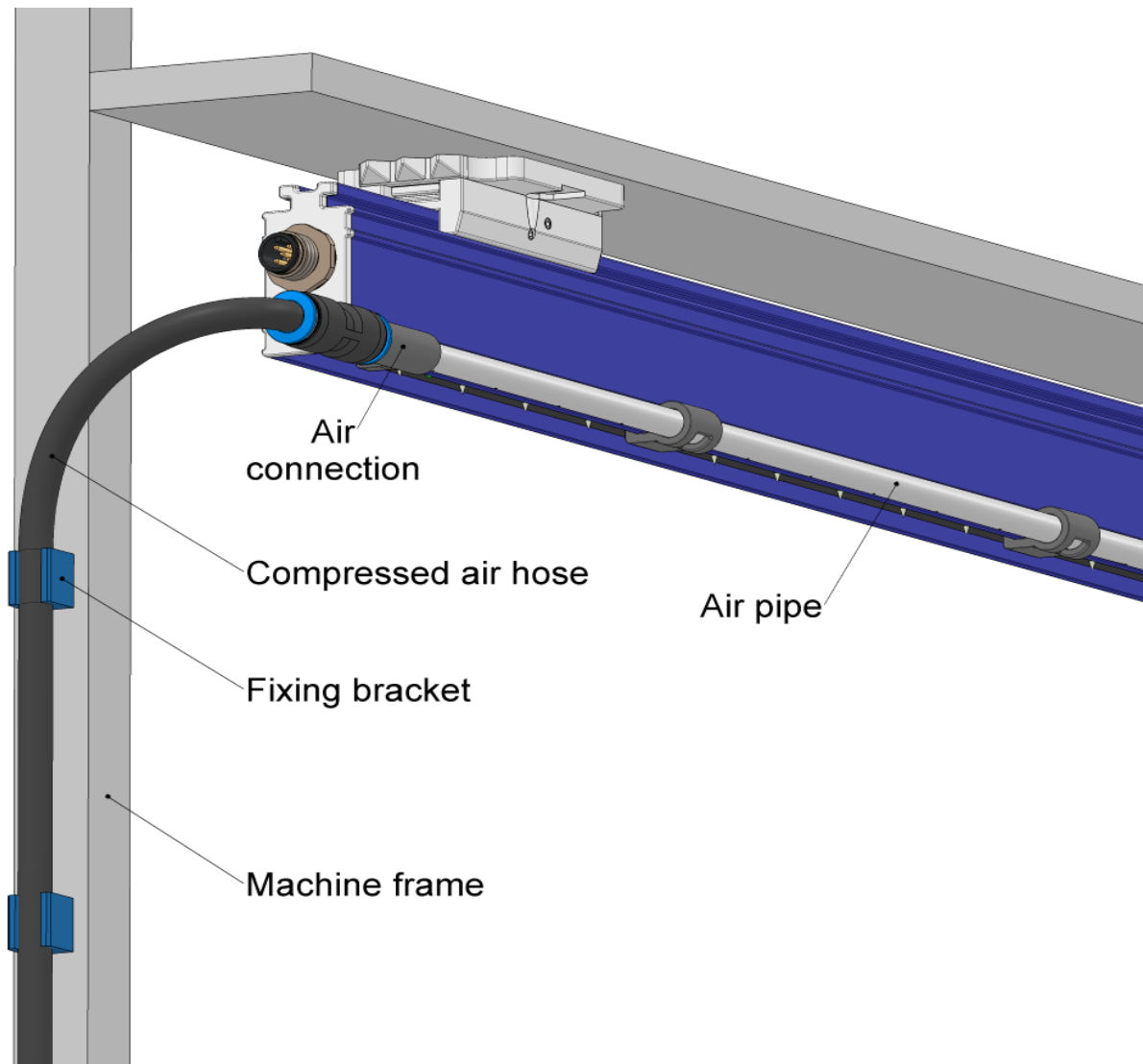

Figure: Mounting example EasION-A IQ 4.x

Inline mounting the EasION 4

The EasION 4 types EasION C IQ 4.1 and EasION R IQ 4.x are designed to be mounted inline to cover wider effective lengths.

When multiple bars are mounted tightly together, the distance between the last and first emitter becomes equal to the emitter spacing of a single EasION.

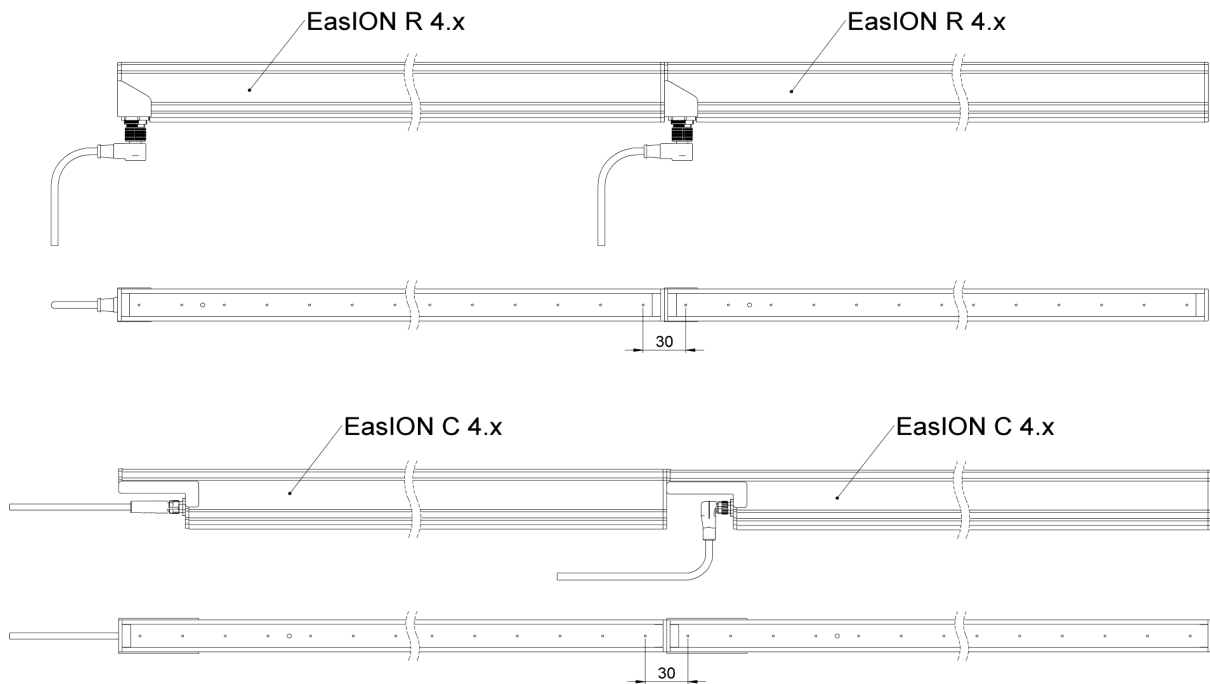

Figure: Inline mounting EasION 4

Electrical connection

Connecting the EasION IQ 4.x



NOTE

- Always use a device connector suitable for the device type.
- When connecting the device connector to the device, never use a torque higher than 0,5 Nm (hand-tight). A higher torque may damage the connector or the device.
- The device male input connector can NOT be rotated. Rotating the connector will damage the device.

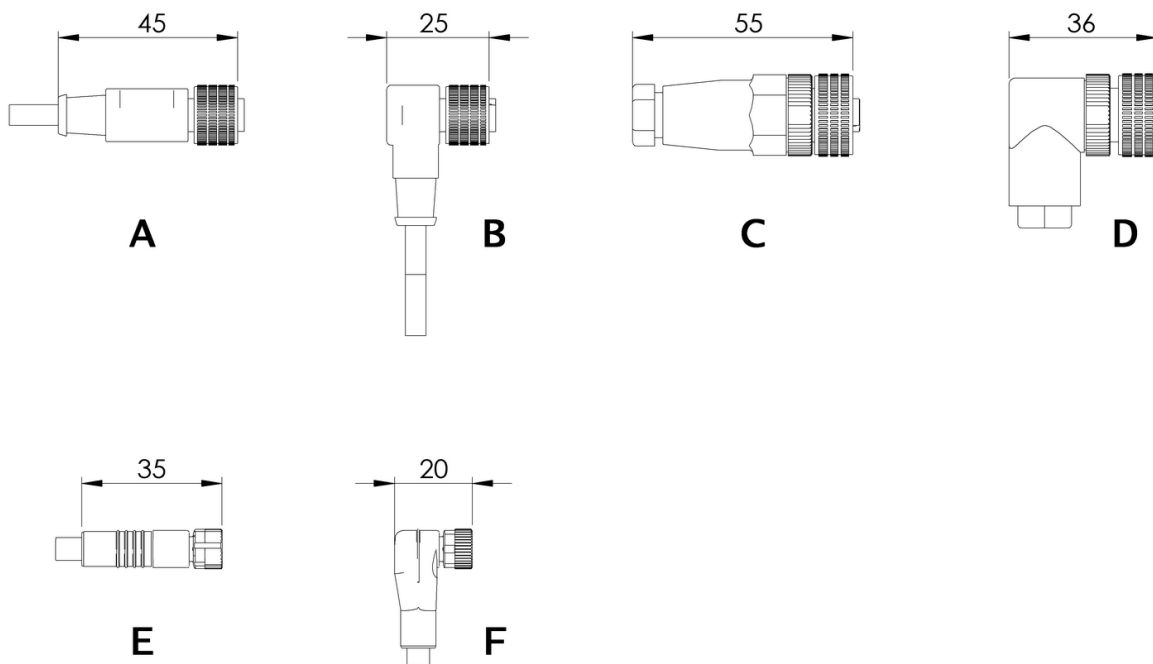

POS	DESCRIPTION	DEVICE TYPE
A, B	M12 Female Connector, 5 pole	EasION(-A) IQ 4.x EasION-R IQ 4.x
C, D	M12 screwable Female Connector, 5 pole	EasION(-A) IQ 4.x EasION-R IQ 4.x
E, F	M8 Female Connector, 5 pole	EasION-C IQ 4.1

Figure: Device connectors dimensions

Supported IQ 4 platform device

Table: *Device support*

Connection (power)	IQ operation	Manual Operation (Non-IQ)
Smart SLC IQ 4.0	EasION IQ 4.0 EasION IQ 4.1	-
Addition SLC IQ 4.0	EasION IQ 4.0 EasION IQ 4.1	-
Manager IQ 4.0	EasION IQ 4.0 EasION IQ 4.1	-
Extension IQ 4.0	EasION IQ 4.0 EasION IQ 4.1	-
Manager IQ Easy 2.0	EasION IQ 4.0	
Extension IQ Easy 2.0	EasION IQ 4.0	
Power supply	-	EasION IQ 4.0 EasION IQ 4.1



IQ OPERATION

Connecting the device to the IQ 4 platform

Smart SLC IQ 4.0 or Addition SLC IQ 4.0

- Connect the device to the Smart SLC IQ 4.0 or Addition SLC IQ 4.0, using a blunt-end cable with a suitable device connector. The connection wire colours correspond to the colours of the Smart SLC IQ 4.0 or Addition SLC IQ 4.0 connectors.
- Screw the power cable with the device connector to the device.



NOTE

The device connector can be plugged in during the Smart SLC IQ 4.0 or Addition SLC IQ 4.0 operation. There is no need to switch it off.

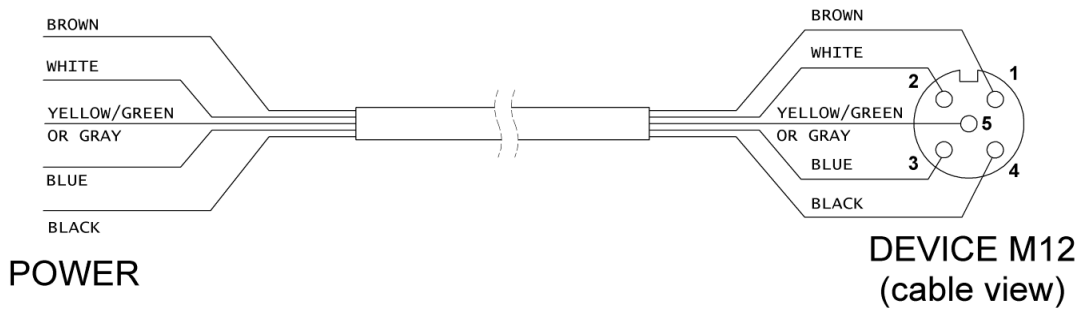

Figure: Wiring Smart SLC IQ 4.0 platform to the device (M12)

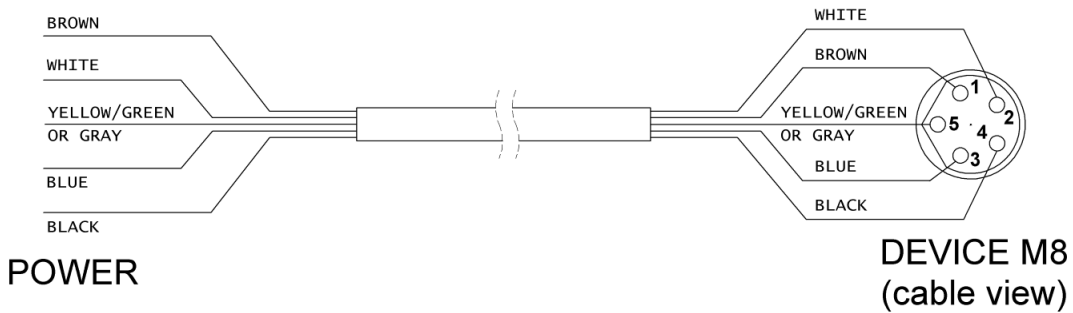

Figure: Wiring Smart SLC IQ 4.0 platform to the device (EasION C IQ 4.x)

Manager IQ 4.0 or Extension IQ 4.0

- Select a free device port on the Manager IQ 4.0 system and connect the M12 female connector.
- Screw the power cable with the device connector to the device.



NOTE

The standard M12 connector can be plugged in during the Manager IQ 4.0 or Extension IQ 4.0 operation. There is no need to switch it off.

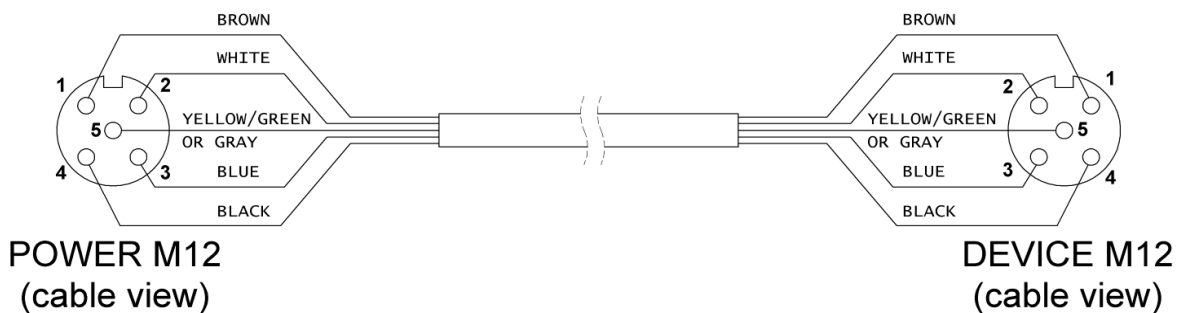

Figure: Wiring Manager IQ 4.0 platform to the device (M12)

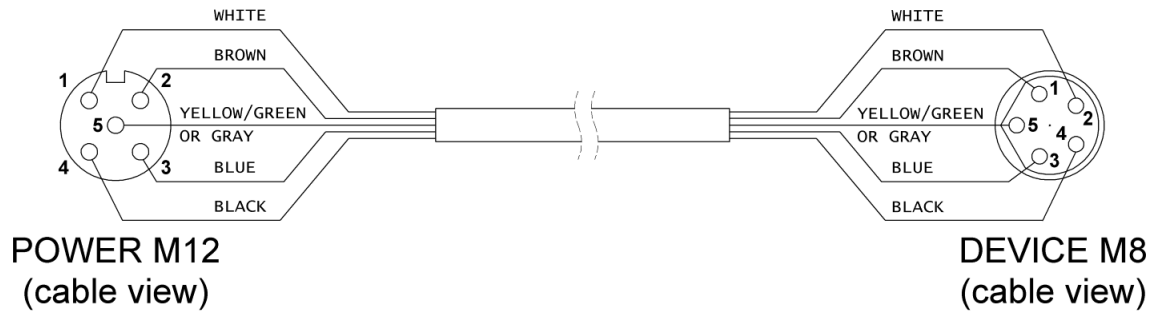

Figure: Wiring Manager IQ 4.0 platform to the device (M8)



MANUAL OPERATION



NOTE

When the device is connected to a DIN rail power supply or an external power supply:

- For personal protection and to ensure proper functioning, the yellow/green or grey and blue wires must be both connected to earth.
- In the Simco-ION desktop power supply and in the IQ 4 platform these connections are already established.

- Screw the power cable with the device connector to the device.
- Connect the other side of the power cable to the 24 V DC power supply according table M12 connection functions.



HINT

Refer to the 24 V DC power supply manual to connect the power supply.







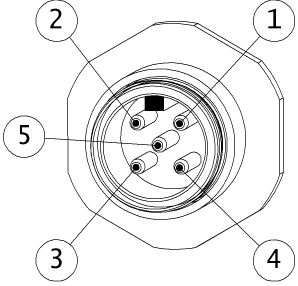
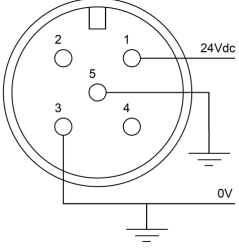

NOTE

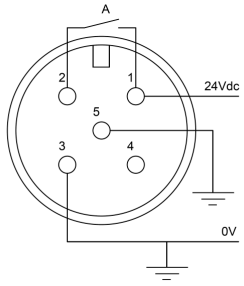
The pin numbers of the M12 connector correspond with the pin numbers of the M8 connector of the EasION C IQ 4.1.

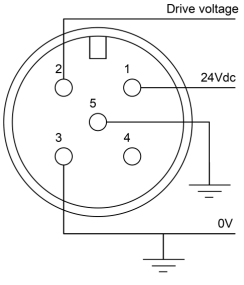
Table: M12 connection functions

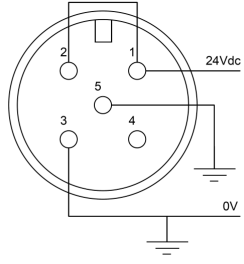
Configuration of the male M12 connector on the device	
	<p>Pin 1 = 24 V DC supply voltage Pin 2 = Remote on input Pin 3 = Ground (0 V) Pin 4 = Operation OK output Pin 5 = Functional ground</p>
Connecting power supply	
	<ul style="list-style-type: none"> • Connect pin 1 of the M12 connector to the positive output terminal of the 24 V DC power supply via the brown wire of the M12 cable. • Connect pin 2 according to one of below options • Connect pin 3 to the 0 V / Gnd output terminal of the 24 V DC power supply via the blue wire of the M12 cable. • Important! Also connect 0 V / Gnd to ground for proper and safe operation. • Important! Connect pin 5 to the ground via the yellow/green or grey wire of the M12 cable for proper and safe operation.

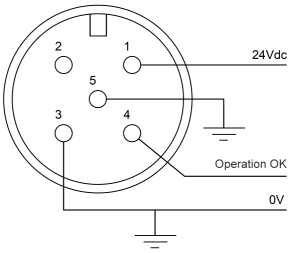
Connecting the Remote on input	
	<p>Option 1, using an external contact</p> <p>Connect pin 2 (white wire) via contact A (relay, switch, etc.) to 24 V DC.</p> <p>The device is active when the contact is closed.</p> <p>The device is inactive when the contact is opened.</p> <div data-bbox="555 421 1390 645" style="border: 1px solid black; padding: 10px; margin-top: 10px;">  <p>HINT To repeatedly switch the device on and off, it is advisable to use the Remote on pin on the M12 connector. This makes the device switch on much faster.</p> </div>
	<p>Option 2, using an external Remote on signal (for example a PLC output)</p> <p>Connect pin 2 (white wire) to an external drive voltage relative to pin 3 (blue wire, 0 V / Gnd).</p> <p>When a drive voltage of 10 - 30 V DC is applied, the device is active.</p> <p>When there is no drive voltage applied, the device is inactive.</p> <div data-bbox="555 981 1390 1205" style="border: 1px solid black; padding: 10px; margin-top: 10px;">  <p>HINT To repeatedly switch the device on and off, it is advisable to use the Remote on pin on the M12 connector. This makes the device switch on much faster.</p> </div>
	<p>Option 3, continuous use</p> <div data-bbox="555 1305 1390 1496" style="border: 1px solid black; padding: 10px; margin-top: 10px;">  <p>NOTE It may take several seconds after powering up before the device is functioning. See chapter Technical specifications.</p> </div> <p>Connect pin 2 (white wire) to 24 V DC; the device will be continuous on.</p>
Connecting the Operation OK output	
	<p>A control device (for instance, a relay or PLC input) can be connected to Pin 4 (black wire) of the M12 connector relative to Pin 3 blue wire, 0 V / Gnd).</p> <p>This output will be high if the device runs without warnings or alarms (24 V DC).</p> <p>If the device is inactive, there is a warning or an alarm, then this output will be low (0 V DC).</p>

Commissioning



IQ OPERATION

If the device is connected to a Smart SLC 4.0 system, it will have IQ functionality.

IQ start up procedure



NOTE

- When the connection cable connects the device and the IQ 4 platform, communication will be established automatically, indicated by flashing status LED.
- Refer to the manual of the IQ 4 platform for details about the IQ functionality.

- Remove the protective cover from the device.
- Perform a device calibration if necessary.
- Switch on the device.
- **EasION-A IQ 4.x:** Adjust the compressed air pressure to optimise the cleaning of the object.

Calibrating the device

An initial device calibration is done at the Simco-ION factory.

To make the efficiency indication more accurate and to incorporate the environmental conditions, calibration must be done:

- At the first commissioning of the device.
- When the position of the device has been changed.

Calibration procedure



NOTE

- Correct calibration can only be performed when the object to be neutralised is in position but not moving (standing still) or if the object to be neutralised is not present.
- The emitter pins must be in good condition and the device must be clean. For cleaning information, see chapter Maintenance.

- Ensure that the device is mounted in the final position.
- Remove the protective cover from the device.
- Calibrate the device using the Smart SLC 4.0.

For calibration instructions refer to the IQ 4 platform user manual.



MANUAL OPERATION

If the device is connected to a 24 V DC power supply without the Smart SLC 4.0 system, it will not have IQ functionality.

Manual start up procedure

- Remove the protective cover from the device
- Switch on the power supply of the device.
- Connect 24 V DC to the device Remote on input (Pin 2)
See chapter Installation/Electrical connection for detailed information.

Manual switch off procedure

- Disconnect the 24 V DC from the device Remote on input (Pin 2).
The device becomes inactive (standby).
or
- Switch off the power supply of the device to completely turn it off.



HINT

- If the device must be repeatedly switched on and off, it is advisable to use the Remote on pin of the device connector. This makes the device switch on much faster. See chapter Electrical connection for more remote on/off details.
- With a desktop power supply provided by Simco-ION, the Remote on/off is already connected internally with the 24 V supply voltage. If this power supply is used, the device will be activated as soon as the power supply is switched on.

Functional check



IQ OPERATION

Functional check via the device status LED

Table: *Status LED indications, IQ operation*

LED indication	Conduct	Status	High Voltage
Green	Flashing 50 ms on/50 ms off for 3 seconds	Initialising	Off
Green	Flashing 500 ms	Standby	Off
Green	On	In operation	On
Orange	On	Clean Bar Indication (CBI)	On
Red	On	Warning: high voltage overload	On
Red	flashing 100 ms	Alarm: no IQ communication	On/Off*

* The high voltage can be on or off, depending on whether the device is/was active or in standby mode.

EasION IQ 4.0 functional ckeck via the Manager IQ Easy 2.0

Refer to the Manager IQ Easy user manual.

Functional check via the Smart SLC 4.0 or Manager IQ 4.0

Refer to the IQ 4 platform user manual.



MANUAL OPERATION

Functional check via the device status LED

Table: *Status LED indications, stand-alone operation*

LED indication	Conduct	Status	High Voltage	Signal operation OK
Green	Flashing 50 ms on/50 ms off for 3 seconds	Initialising	Off	Off
	Flashing 100 ms on/100 ms off for 3 seconds			
Green	Flashing 500 ms	Standby	Off	Off
Green	On	In operation	On	On
Red	On	Warning: high voltage overload	Regulated	Off
Red	Flashing 1Hz	Operation OK overloaded	On	Off

Causes of overloading

Possible causes of overload of the high voltage:

- Contamination of the device.
- Direct contact between conductive material and emitters.
- The device is mounted too close to conductive (machine) parts.

Possible causes of overloading of the Operation OK signal:

- Short circuit of the Operation OK signal.
- Overload on the Operation OK signal.

Maintenance

General maintenance rules

- Keep the device clean and dry.
- Switch off the device before cleaning.
- Clean the device regularly to improve the operation.
- Check the connection cable(s) periodically for damage.

Regular cleaning



NOTE

The cleaning interval time depends on the type and degree of contamination. The higher the degree of environmental contamination, the shorter the cleaning interval must be.

- Brush the dirty parts with a hard, non-metallic brush.
- Vacuum the device or blow it off with clean compressed air (max. 6 bar).



NOTE

If the result of dry cleaning is not satisfactory, continue with wet cleaning.

Wet cleaning with a damp cloth

- Clean the device and the connection cable(s) with a suitable cleaning agent (e.g. isopropyl alcohol).

Veconova 10 can also be used for stubborn dirt (www.eco-nova.nl).

- Only clean the outside of the device.
- Allow the device to dry completely before switching it on again.

Troubleshooting



IQ OPERATION

Table: *Faults when connected to an IQ 4 platform*

LED signalling	Issue	Cause	Solution
Off	No high voltage on the emitters	No supply voltage	Switch on the Smart SLC 4.0 or Manager IQ 4.0 system or enable the device
		Wiring fault	Locate the fault and repair the wiring
Flashing green (1 Hz)	No high voltage on the emitters	Device in standby mode	Turn on the device using the Smart SLC 4.0 or Manager IQ 4.0 (run mode)
Continuously red	Device overload	The device is contaminated	Clean the device
		Device mounted too close to conductive machine parts	Move the device
Continuously orange	Poor ionisation, but high voltage on the emitters	Emitters are covered	Remove the cover
		Device is dirty	Clean the device
		Device positioned incorrectly	Reposition the device
		Emitters are damaged	Replace the device
Flashing red (1 Hz)	High voltage present but not maximum	Supply voltage too low	Check 24 V DC Smart SLC 4.0 or Manager IQ 4.0 or Replace the connection cable with one with a larger diameter or Shorten the connection cable
		Internal device temperature too high	Check for metal parts close to the device
			Check the device environment temperature
Flashing red (5 Hz)	No communication with the IQ 4 platform	Wiring fault	Locate the fault and repair the wiring



MANUAL OPERATION

Table: *Faults when connected to a 24 V DC power supply*

LED signalling	Issue	Cause	Solution
Off	No high voltage on the emitters	No supply voltage	Switch on the power supply
		Wiring fault	Locate the fault and repair the wiring
		Power supply with insufficient capacity	Use certified power supply, see chapter spare parts
Flashing green	No high voltage on the emitters	No Remote on/off signal	Connect/activate the Remote on/off functionality
		Wiring fault	Locate the fault and repair the wiring
Continuously red	Device overloaded	Device is contaminated	Clean the device
		Device mounted too close to conductive machine parts	Move the device
Continuously green	Poor ionisation, but high voltage on the emitters	Emitters are covered	Remove the cover
		Device is dirty	Clean the device
		Device positioned incorrectly	Reposition the device
		Emitters are damaged	Replace the device
Flashing red (1 Hz)	High voltage present, no operation OK signal	Operation OK output overloaded	Reduce load of the operation OK output
		Wiring fault	Locate the fault and repair the wiring
Flashing red (5 Hz)	n.a.	During power-up, the possibility of communication is checked	Ignore during power-up

Warranty

The Simco-ION warranty conditions are described in and published on the internet.
These conditions can be viewed on:

https://www.simco-ion.co.uk/wp-content/uploads/Extended-warranty-conditions_GB.pdf

Simco-ION Warranty Conditions GB

Warranty Period

The device has a one-year warranty as standard, which commences on the invoice date.

The warranty becomes four years by registering the device on the Simco-ION website.

To register the device, it is necessary to state the serial number of the device. This information can be found on the device nameplate.

<https://www.simco-ion.co.uk/warranty>

Warranty registration site GB

Repairs

Review these conditions before submitting equipment for repair (RMA procedure) to Simco-ION.



NOTE

- Only Simco-ION can and may repair this product.
- In the event of a defect within or outside the warranty, the product can be offered to Simco-ION for repair.

- Refer to the problem analysis in chapter Troubleshooting, and follow the advice.
- If it is certain that the Simco-ION product causes the problem, offer it for repair.
- Use the RMA procedure before offering the product to Simco-ION.

Return Merchandise Authorisation

In case of problems and questions, please get in touch with Simco-ION or a Simco-ION representative in your region.

A malfunctioning or defective product can be returned to Simco-ION for repairs following the RMA (Return Merchandise Authorisation) procedure below.

RMA Request

- Fill in the Simco-ION RMA form at <https://www.simco-ion.nl/repair> or <https://www.simco-ion.co.uk/repair>
- By entering the item and serial numbers, you can determine whether your product will be repaired under warranty or if costs are involved.

Return sending

- Pack the defective product properly.
- Indicate the RMA number on the package.
- Send the package to the stated return address of Simco-ION.

Storage and disposal

Storage

Always store the Simco-ION products in a dry and cool place.

Disposal

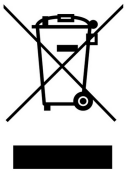

- When disposing of the product, follow the local environmental regulations.
- Do not dispose the product with regular waste at the end of its life, but offer it at an official point. This way, you help to protect the environment.

Spare parts

Table: *General spare parts*

No	Part number	Product image	Description	Comment
1	4532000100		Mounting Bracket Bars	
2	7519020365		Device-cable M12 female straight 5 m	
	7519020366		Device-cable M12 female straight 10 m	
3	7519020375		Device-cable M12 female right angled 5 m	
	7519020376		Device-cable M12 female right angled 10 m	
4	4524001200		Power supply 100-240 V/24 V 3m, Simco-ION Desktop power supply	
	7519020425		Simco 100-240 V/24 V Din-rail Power Supply	
	7519020430		Simco 100-240 V/24 V UL Din-rail Power Supply	
5	7524000155		Bracket T-slot stainless steel (long)	
6	7524000156		Bracket w. steel thread M6x8 stainless steel	
7	7524000157		Bracket w. steel thread M6x35 stainless steel	

Closing

Simco (Nederland) B.V.
Aalsvoort 74
7241MB LOCHEM
Phone +31 573 288 333
Email cs@simco-ion.nl
Internet <https://simco-ion.eu/>